

## DSV2-100

### Four-Way, Two-Position, Spool-Type Cartridge Solenoid Valve

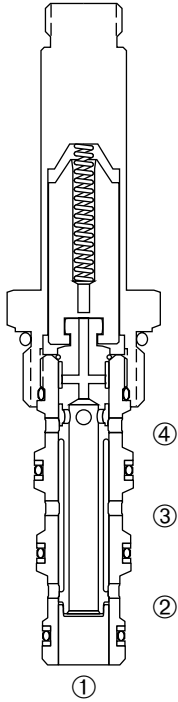

#### DESCRIPTION

A cartridge valve designed as a four-way, spool-type, directional control valve, with all ports normally-open. This valve is commonly used in a circuit to allow flow to and from a double-acting cylinder or motor.

#### OPERATION

When de-energized, the DSV2-100 allows flow from ③ to ② and from ④ to ①.

When energized, the cartridge's spool shifts and allows flow from ③ to ④ and from ② to ①.

**Operation of Manual Override Option:** To override, push button in, twist counterclockwise and release. In this position, valve will remain detented in the shifted condition.

To return to normal operation, push button in, twist clockwise and release. Override will be detented in this position.

#### SYMBOL

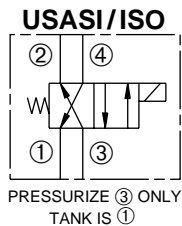

#### FEATURES and BENEFITS

- Continuous-duty solenoid.
- Hardened precision spool and sleeve for long life.
- Efficient wet-armature construction.
- Cartridges are voltage interchangeable.
- Optional coil voltages and terminations.
- Manual override option.
- Industry common cavity.
- Compact size.

#### PRESSURE DROP VS. FLOW

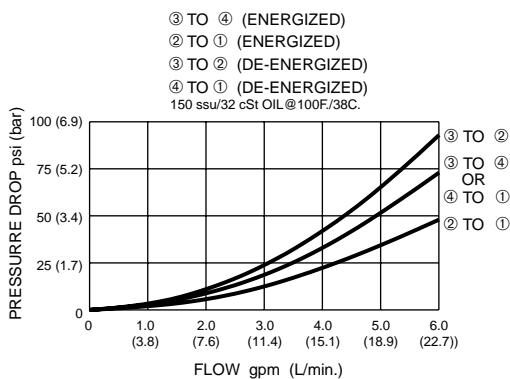

#### SPECIFICATIONS

**Operating Pressure:** 3000 PSI (207 Bar)

**Flow:** See PRESSURE DROP VS. FLOW graph.

**Internal Leakage:** (Per land) 5 in.<sup>3</sup>/min. (82 cc/min.) max. at 3000 PSI (207 Bar)

**Temperature:** -30° F to +250° F (-35°C to +120° C)

**Coil Rating:** Continuous from 85% to 110% of rated voltage.

**Current Draw:** 12 VDC is 1.7 amps.

**Minimum Pull-In Voltage:** 85% of rated voltage at 3000 PSI (207 Bar)

**Response Time:** 80% of final change of state with 100% voltage supplied at 100% of nominal flow rating.

**Pull-In:** 12 VDC 30 m. sec.

**Drop-out:** 12 VDC 120 m. sec.

**Recommended Filtration:** ISO 16/12

**Fluids:** Mineral-based fluids.

For other fluid compatibility consult factory.

**Cavity:** 100-4, see page 0.21.

**Cavity Tool:** See page 0.21.

**Body Material:** Anodized 6061T6 aluminum alloy rated at 3000 PSI (207 Bar).

## INSTALLATION DIMENSIONS

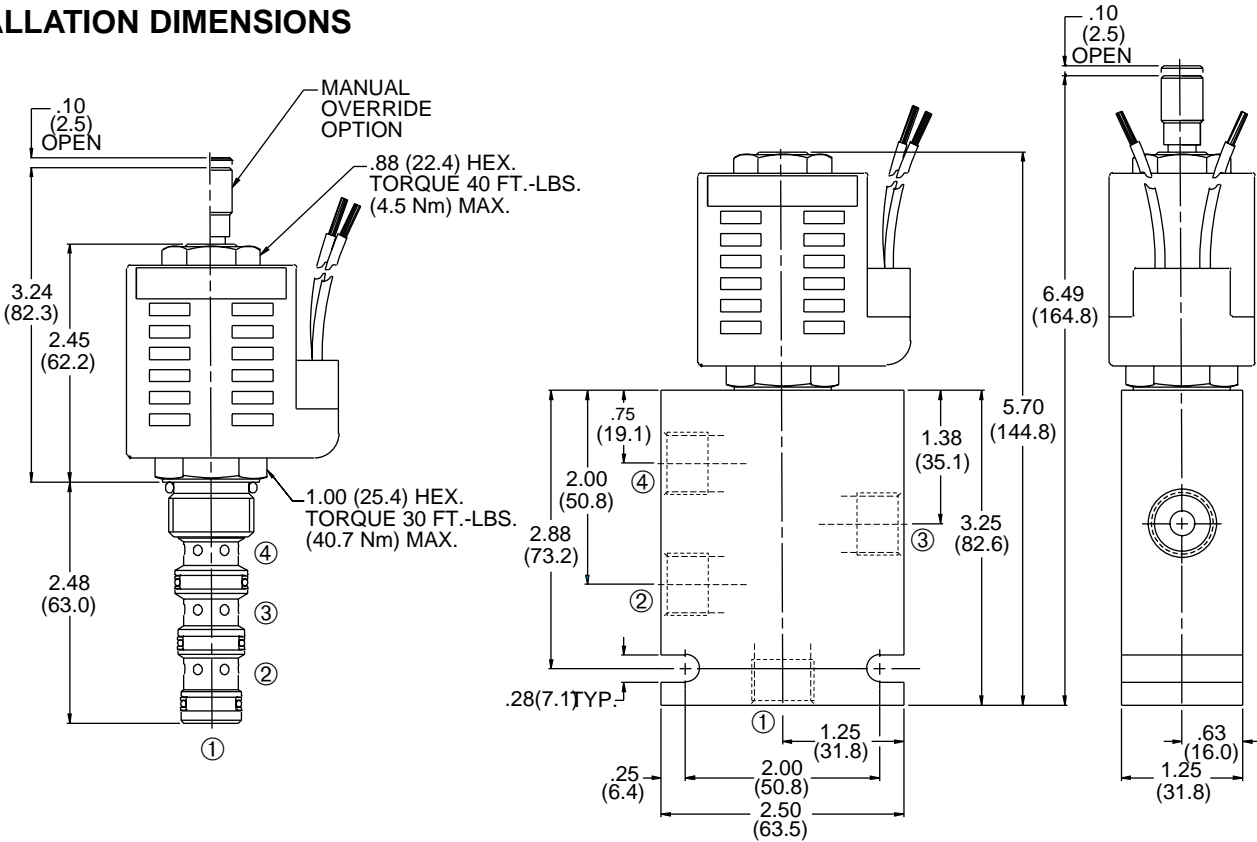

( ) Parentheses = Millimeters

## HOW TO ORDER

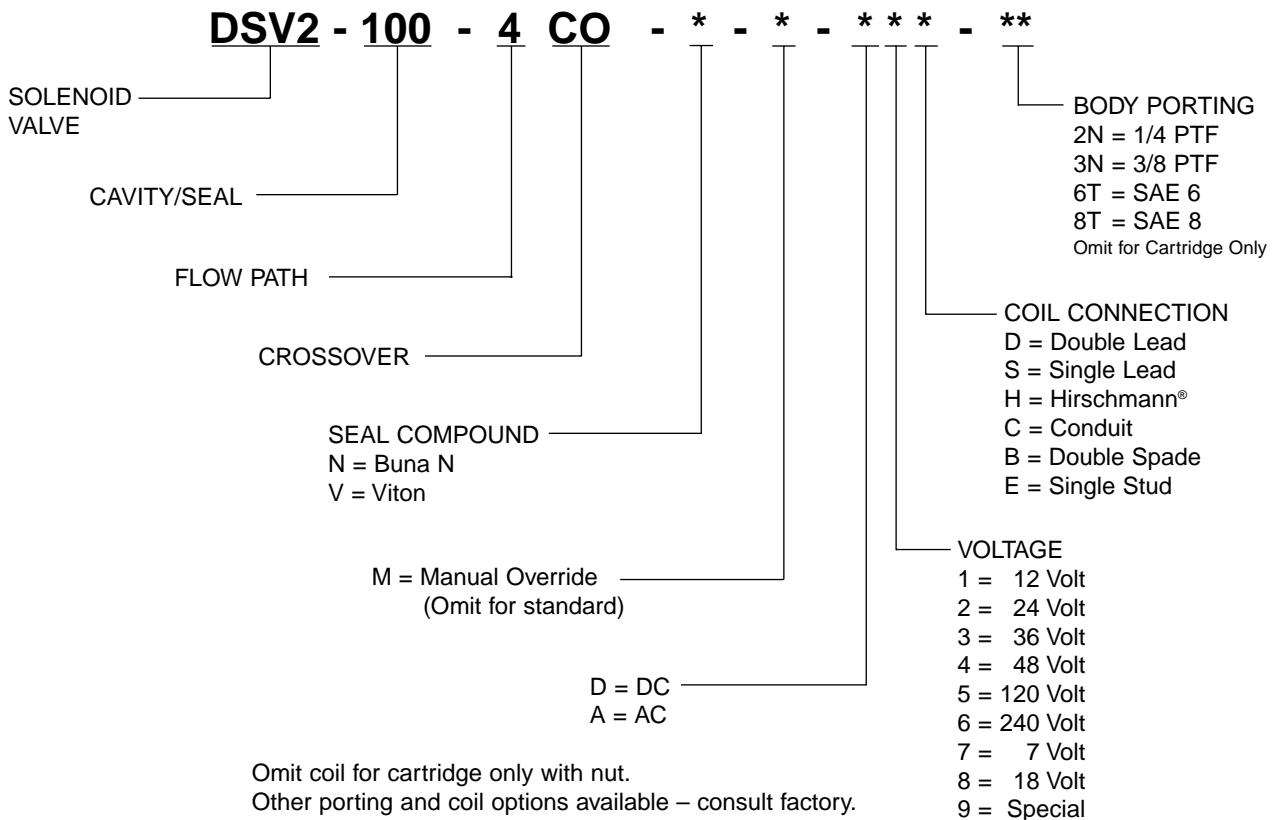

Omit coil for cartridge only with nut.  
Other porting and coil options available – consult factory.