

## DRV-100

### Adjustable, Direct-Acting Cartridge Relief Valve

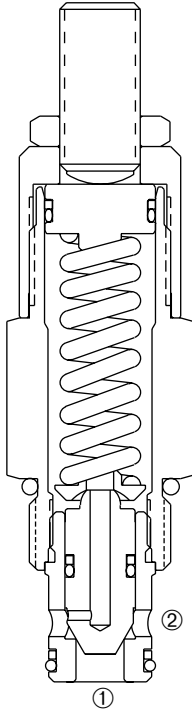

#### DESCRIPTION

An adjustable, direct-acting poppet cartridge valve designed to limit pressure in hydraulic circuits.

#### OPERATION

The DRV-100 prevents flow from ① to ② until the set crack pressure at ① is achieved. The poppet then unseats allowing flow from ① to ② protecting the circuit from over pressurization.

#### SYMBOL

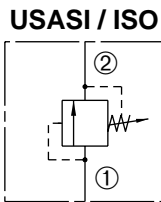

#### FEATURES and BENEFITS

- Rapid response to pressure surges.
- Hardened poppet and seat for long life.
- Hidden adjustment (tamper resistant) option.
- Aluminum knob and disc nut option.
- Adjustment may be locked in place.
- Adjustment prevents spring from going solid.
- Industry common cavity.
- Compact size.

#### PRESSURE DROP VS. FLOW

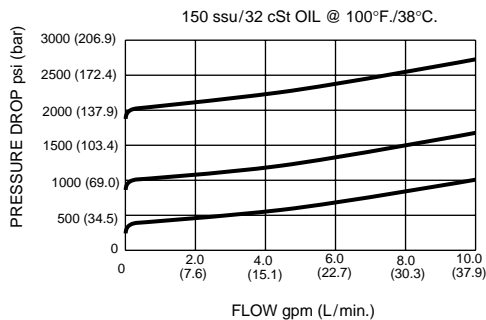

#### SPECIFICATIONS

- Operating Pressure:** 3000 PSI (207 Bar)
- Flow:** See PRESSURE DROP VS. FLOW graph.
- Internal Leakage:** 20 drops/min. max. at reseal.
- Crack Pressure Defined:** Determined at .25 GPM (0.9 L/min.)
- Reseat Pressure:** Nominal 80% of crack pressure.
- Spring Ranges:**
  - 100 to 400 PSI ( 7 to 28 Bar)
  - Preset: 300 PSI ( 21 Bar)
  - 300 to 1000 PSI ( 21 to 69 Bar)
  - Preset: 500 PSI ( 34 Bar)
  - 300 to 2000 PSI ( 21 to 135 Bar)
  - Preset: 1500 PSI (103 Bar)
  - 1500 to 3000 PSI (103 to 207 Bar)
  - Preset: 2500 PSI (172 Bar)
- Temperature:** -30°F to +250°F (-35°C to +120°C).
- Recommended Filtration:** ISO 19/15
- Fluids:** Mineral-based fluids.  
For other fluid compatibility consult factory.
- Cavity:** 100-2, see page 0.21
- Cavity Tool:** See page 0.21
- Body Material:** Anodized 6061T6 aluminum alloy rated at 3000 PSI (207 Bar).

## INSTALLATION DIMENSIONS

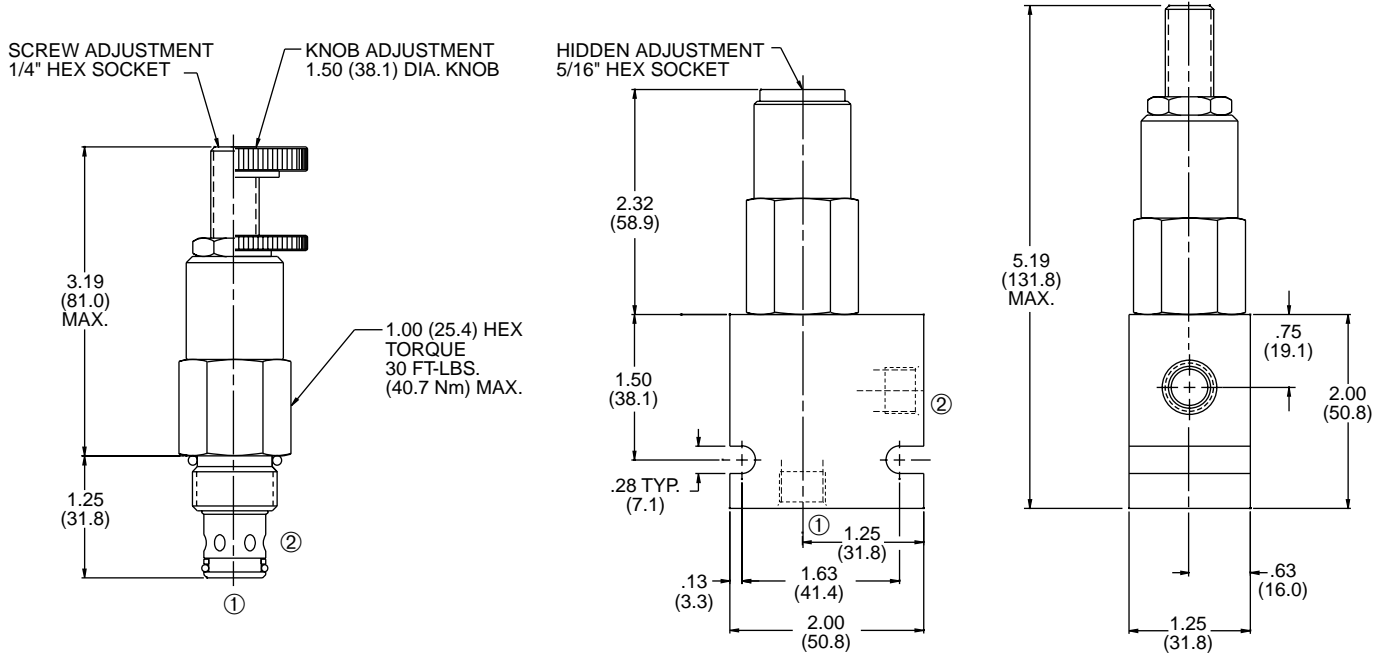

( ) Parentheses = Millimeters

## HOW TO ORDER

